

CELEBRATING  
**75**  
YEARS  
RED HEART YARNS 1936 - 2011

# REDHEART.COM

## RED HEART'S 75TH ANNIVERSARY

# BIG GIVEAWAY

SEPTEMBER 1ST - OCTOBER 11TH

ENTER NOW FOR A CHANCE TO WIN

## PRIZE INCLUDES

- \$75 of Red Heart Yarn Supplies
- AND**
- 1 Year subscription to Knitting Today! or Crochet Today!



**75** = 12 WINNERS

**ENTER TO WIN!**

Have you ever wondered how your favorite yarn is made - right here in the USA? Enter now for your chance to win the

# ★ GRAND PRIZE ★

All-Expense Paid Trip for 2  
to tour the Red Heart Mill  
in Albany, GA  
(Prize valued at \$1,500)



GEORGIA



# Bam Bam Bath Set

Designs by Kennita Tully

*Cuddle your child after bath time in a warm and thick robe with matching slippers.*

## Skill Level

Beginner\*

## Size

Child's small (medium, large)  
Instructions are given for smallest size, with larger sizes in parentheses. When only 1 number is given, it applies to all sizes.

## Finished Measurements

**Chest (closed):** 34 (36, 38) inches

**Length:** 25 (26, 27) inches

## Materials

- Plymouth Bam 42 percent acrylic/40 percent nylon/18 percent wool bulky weight yarn (60 yds/50g per ball): Bathrobe: 13 (15, 17) balls; Slippers: 1 (1, 2) balls lagoon #3463
- Size 10 (6mm) needles or size needed to obtain gauge for slippers
- Size 13 (9mm) needles or size needed to obtain gauge for robe
- Stitch holders
- Stitch markers
- Tapestry needle



## Gauge

10 sts and 14 rows = 4 inches/10cm in Seed st for bathrobe.

11½ sts and 22 rows = 4 inches/10cm in garter st for slippers. To save time, take time to check gauge.







## Pattern Stitch

**Seed Stitch** (odd number of sts)

**All rows:** \*K1, p1; rep from \* across, end last rep k1.

# Bathrobe

## Back

With larger needles, cast on 41 (45, 49) sts.

Work even in Seed st for 18 inches.

Mark each end st for underarm.

Continue to work even in established pat for 7 (8, 9) inches more.

Bind off all sts.

Mark center 13 (15, 17) sts for back neck.

## Right Front

With larger needles, cast on 25 (27, 29) sts.

Work even in Seed st until front measures same as for back, placing marker for underarm at right edge after 18 inches.

### Shape back collar

**Next row (WS):** Bind off 14 (15, 16) sts at beg of row.

Continue to work even on remaining

11 (12, 13) sts until collar measures 3 (3¼, 3½) inches above bound-off row.

Bind off.

## Left Front

Work as for right front, reversing shaping.

## Sleeves

With larger needles, cast on 17 (21, 25) sts.

Working in Seed st, inc 1 st at each end on 3rd row, then [1 st each end every 4th row] 9 times more. (37, 41, 45 sts)

Work even until sleeve measures 13 inches.

Bind off.

## Belt

Cast on 7 sts.

Work even in Seed st until belt measures 48 inches.

Bind off.

## Finishing

Sew shoulders. Sew back collar extensions along short edge.

Sew collar to back neck.

Sew sleeves into armhole between underarm markers.

Sew side and sleeve seams.

## Slippers

With smaller needles, leaving an 8-inch tail, cast on 17 (21, 23) sts.

Work even in garter st until slipper measures 1 (1¼, 1½) inches less than desired foot measurement.

### Shape toe

**Row 1:** K2, \*p1, k1;

rep from \* across, end last rep k2.

**Row 2:** P2, \*k1, p1; rep from \* across, end last rep p2.

[Rep Rows 1 and 2] 2 (2, 3) times.

Cut yarn leaving an 8-inch end for sewing.

Draw end through all sts, pull tightly to secure and sew ribbed section.

Fold cast-on edge in half to form back seam.

With tail of yarn from cast-on edge, sew edges tog for heel. ♦



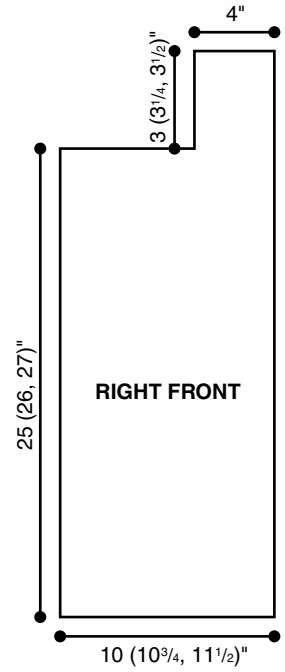
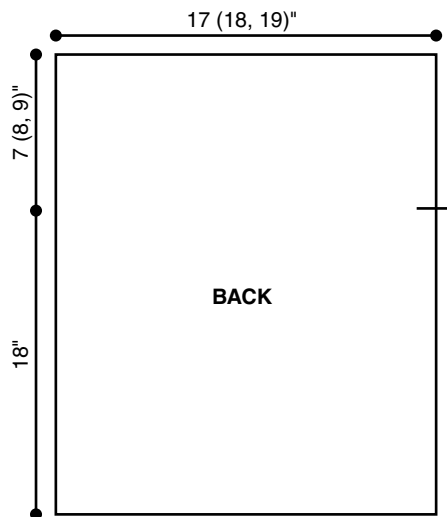
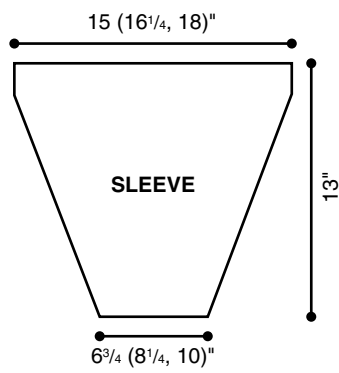



# Which of these *kit clubs* would YOU enjoy the most?

**BEADING**

Learn the latest **BEADING** tips and techniques!



*Simply Beads*  
Kit-of-the-Month Club®

**Learn More!**

**KIDS CRAFTS**

Fun, creative craft kits designed **JUST FOR GIRLS!**



*Creative Girls Club*

**Learn More!**

**CARD MAKING**

Get tips, techniques, inspiration and **CARD MAKING** materials every month!



**CardMaker**  
Kit-of-the-Month Club

**Learn More!**

**CROCHET & KNITTING**

Double your fun with instructions for both **CROCHET & KNIT!**



*Katie's Hook & Needle Kit Club*

**Learn More!**

**PAINTING**

Become an accomplished watercolor and acrylic **ARTIST** in no time!



**Creative Painter**

**Learn More!**

**CRAFTS**

Explore many **CRAFTING** techniques!



*Creative Woman*  
Kit-of-the-Month Club®

**Learn More!**

**HOLIDAY CRAFTS**

Make beautiful, unique **ORNAMENTS** each month!



*Christmas Ornament*  
Kit of the Month Club

**Learn More!**

**KIDS WOODWORKING**

Real **HAMMER AND WOOD KITS** designed just for kids!



**YOUNG WOODWORKERS KIT CLUB**

**Learn More!**

**QUILTING**

Fabulous **FABRICS** that will inspire you to create!



*Creative Quilters Fabric Club*

**Learn More!**

Visit  
[KitClubCentral.com](http://KitClubCentral.com)